



INSTRUCTIONS

E8M AND E10M IMPLEMENT MOUNTING BRACKET MODEL AP54

1. Remove the mid-mounted mower from the tractor as outlined in the tractor Use and Care Manual.
2. Insert the two short bracket supports in the frame bushings near the front axle. See Figure 1.
3. Secure the tube portion of the mounting bracket between the rear pair of frame bushings by passing the short shaft through the bushings and the bracket tube.
4. Secure the short shaft with a hair pin cotter at each end.
5. Attach the lower ends of the front bracket supports to the holes near the forward end of the mounting bracket with 1/2-13 x 1-inch bolts, lockwashers and nuts.

To remove, follow the same steps in the reverse order.

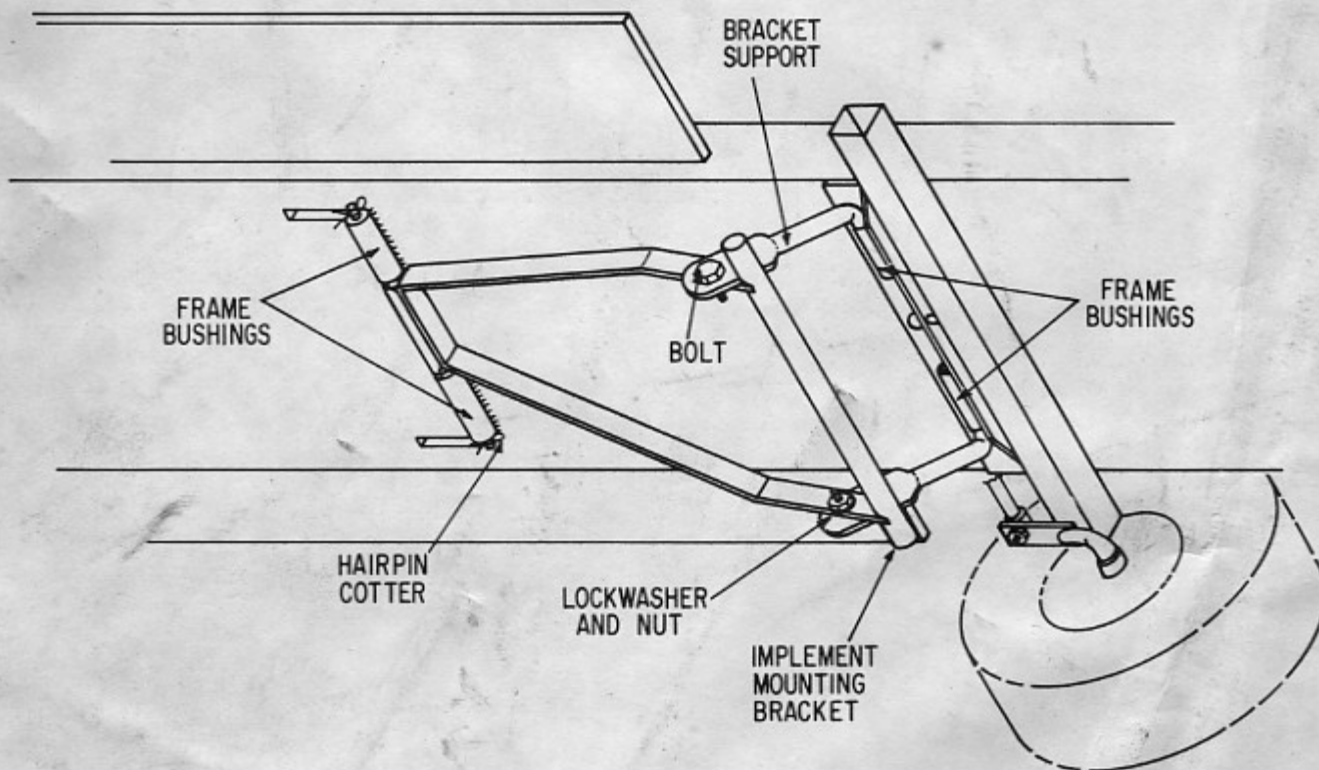

Figure 1 Bottom View (Wheel and steering not shown for clarity only)

PACKING LIST

E8M/E10M Implement Mounting
Bracket Assembly

AP54AA (155C8150G1)

<u>Qty.</u>	<u>Name</u>	<u>Part No.</u>
1	Mounting Bracket	155C8143G1
1	Shaft	244A7395P1
2	Hair Pin Cotter	243A4543P3
2	Support	244A7367P1
2	Bolt, Hex Hd. 1/2 - 13 x 1"	N22P2901GB6
2	Lockwasher 1/2"	N405P15C6
2	Nut, Hex 1/2" - 13	N258P29B6