



Electrak[®]

GEH-4025

Tractor

FORK LIFT

Models CF48, CF74, CF92

Including CF65 Counterweights And CF66 Overhead Guard

ASSEMBLY AND INSTALLATION



GENERAL  ELECTRIC

FORKLIFT ASSEMBLY

1. Cut the banding straps and shipping wires. Remove the forks and loose packages of hardware.
2. Unbolt and remove the angle supports and retain the hardware for reuse.
3. Remove the mounting arms.
4. Remove the control lever, extension and knob.

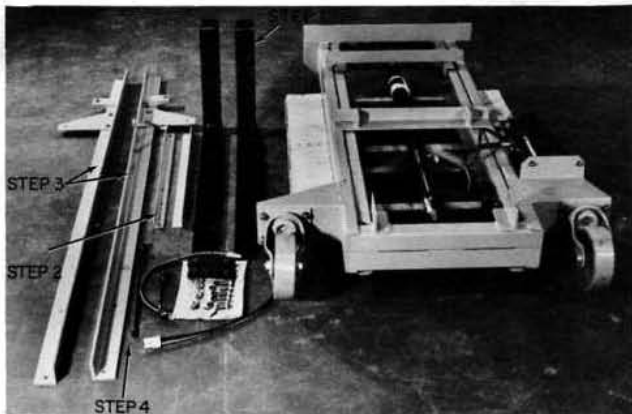

Figure 1

5. Remove the fork lift motor cover, exposing the motor connections, and connect the orange jumper wire from the motor terminal marked "+" to the upper switch terminal. Slide the boot over the switch terminal. Connect the black harness wire to the other motor terminal. Hold the wire in the position shown while tightening the connection. Connect the orange harness wire to the lower switch terminal and slide the boot over the

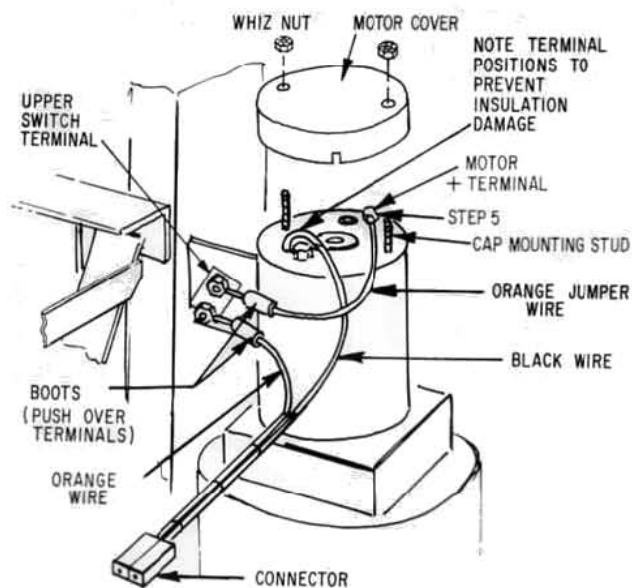

Figure 2

terminal. Turn the wire terminals towards the center of the motor to prevent insulation damage when the cover is replaced. Replace the cover so that the wires exit the cover cutout towards the rear of the lift.

WARNING: Assure correct motor polarity connection, as operation with improperly connected motor will damage the pump.

6. Mount the angle support with the control lever brace to the motor end of the center cross-bar on the lift frame, using a 1/2 x 1 inch bolt, lockwasher and nut. Mount the other angle support similarly at the opposite end of the cross-bar.

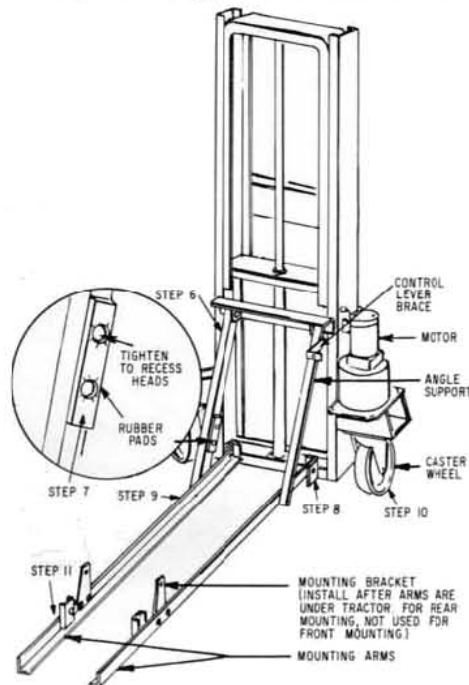

Figure 3

7. Mount rubber pads on the inside of each angle support using carriage bolts (round heads) and nuts. Install the bolts with the heads towards the center of the lift. Tighten the bolts to slightly recess their heads below the rubber pad surface.

8. Install the mounting arms on the lower cross-bar using 1/2 x 1 inch bolts, lockwashers and nuts. Notice that there is a left and right arm.

9. Attach the lower ends of the angle supports to the mounting arm holes using 1/2 x 1 inch bolts, lockwashers and nuts. Using the holes towards the free ends of the mounting arms provides additional rearward tilt to the forks.

10. Attach the caster wheels to the mounting pads with 1/2 x 1 inch bolts, lockwashers and nuts (on CF48 and CF74).

11. The mounting arms should now be in a vertical position. Pull down on the free ends of the arms to rotate the lift on its wheels.

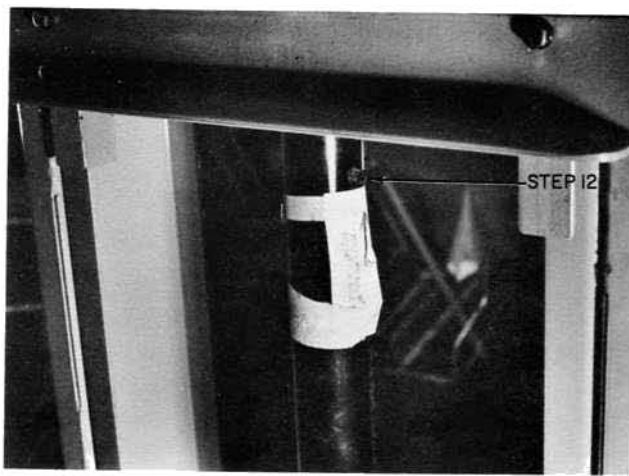

Figure 4

12. **IMPORTANT!** Replace the solid plug near the top of the hydraulic cylinder with the breather plug provided.

13. Insert the control lever rod through the hole in the support, and screw it into the top of the actuating lever. Screw in the longer-threaded end and fully thread on the knob.

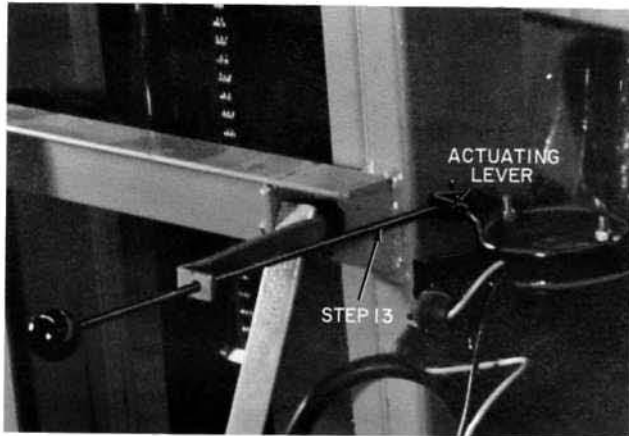

Figure 5

NOTE: For front mounting add the extension as outlined in "Front Installation", step 7. For rear mounting, screw the knob on the control lever rod without using the extension.

14. Install a 3/8 x 1 inch bolt, lockwasher and nut as illustrated in the holes located at each end of the back plate top surface.

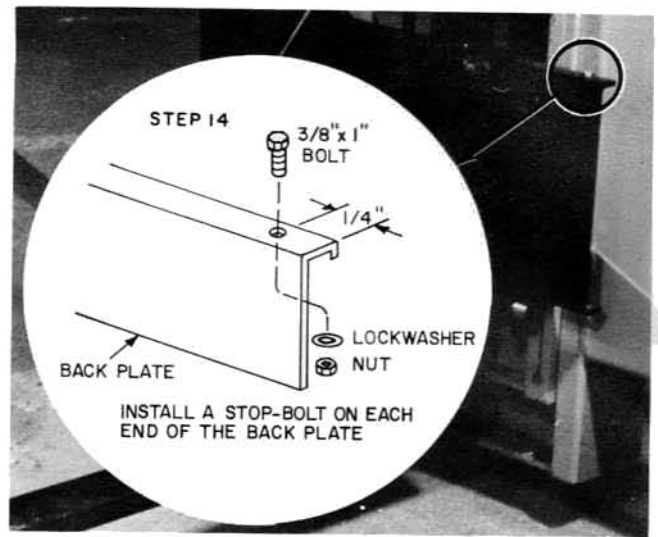

Figure 6

LIFT AND COUNTERWEIGHT INSTALLATION

FRONT MOUNTING

1. Position the Fork Lift assembly with its angle-iron mounting arms towards the front of the tractor.

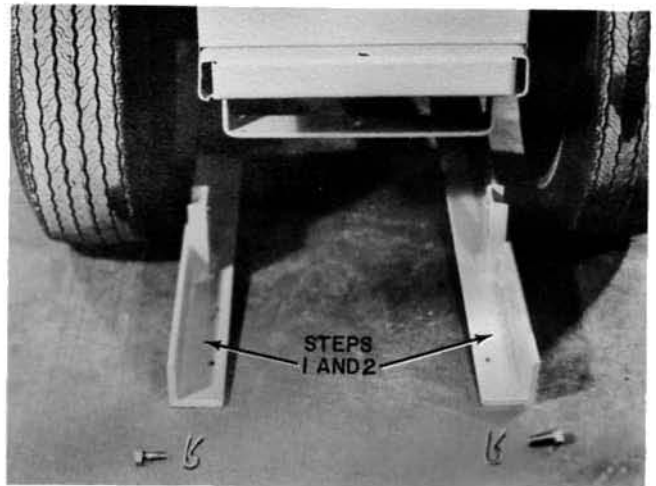

Figure 7

2. Carefully position the tractor over the lift arms so that the mounting arms are fully straddled.



Figure 8

3. Raise the free ends of the mounting arms until the holes in the tractor hitch bale align with the holes in the arms. Secure with clevis pins and hair pin cotters, with the pins' heads towards the tires.

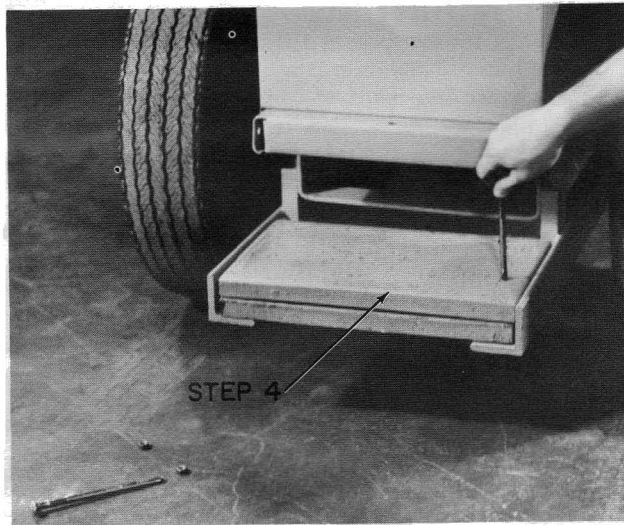

Figure 9

4. Place one of the five counterweight plates on the free end of the mounting arms, aligning the weight holes with the corresponding holes in the arms with the long through-bolts. Add the other four weights, aligning the holes after each one has been placed. Secure the weights with bolts, lockwashers and nuts.

5. Connect the lift motor plug with the lift receptacle under the hood.

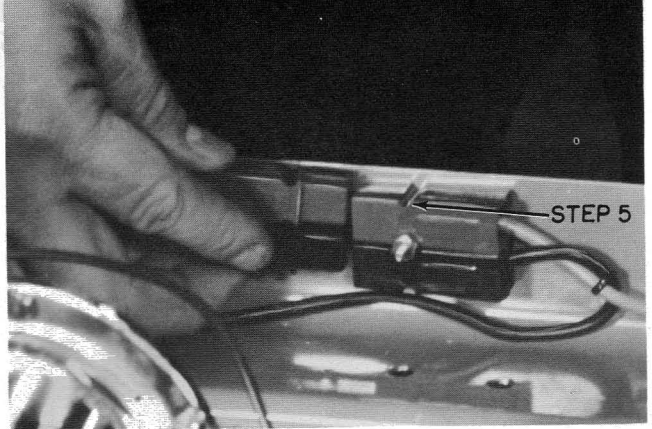

Figure 10

6. Raise the lift to allow the forks to be installed on the back plate.

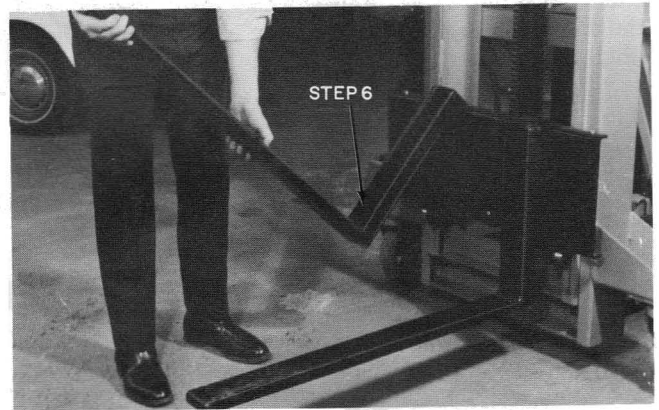

Figure 11

7. Install the Control Handle Extension and knob. Screw on the coupler fully before adding the extension and knob.

Removal follows these steps in the reverse order.

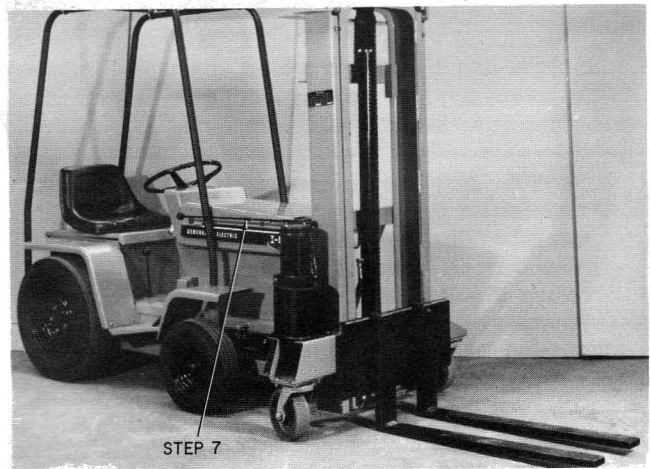

Figure 12



Figure 13

3. Install both triangular mounting bracket plates on the inside of the mounting arms with their beveled sides forward. Secure with 4 sets of bolts, nuts and lockwashers, with the bolt heads outward.

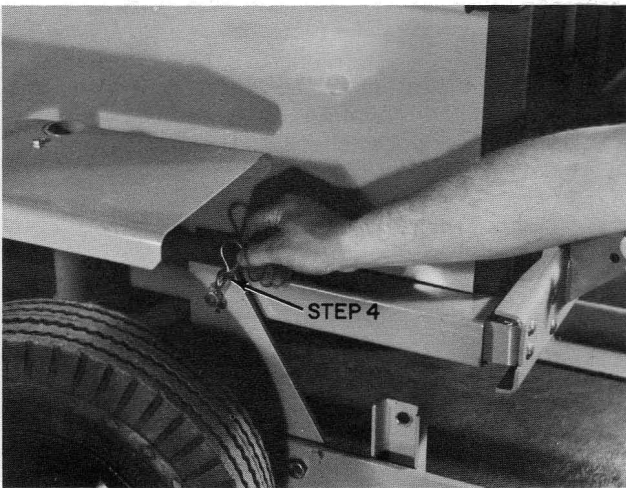

Figure 14

4. Raise the free ends of the mounting arms until the holes in the tractor frame align with the holes in the mounting brackets. Slide the clevis pins through the mounting bracket holes and secure them with the hair-pin cotters.

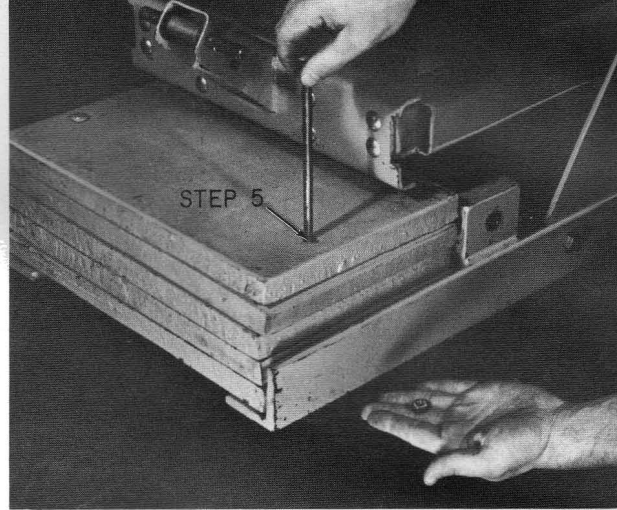

Figure 15

6. Remove the control handle extension if it is installed. Screw the knob onto the control handle.

7. Connect the lift motor plug with the lift receptacle located under the left rear fender.

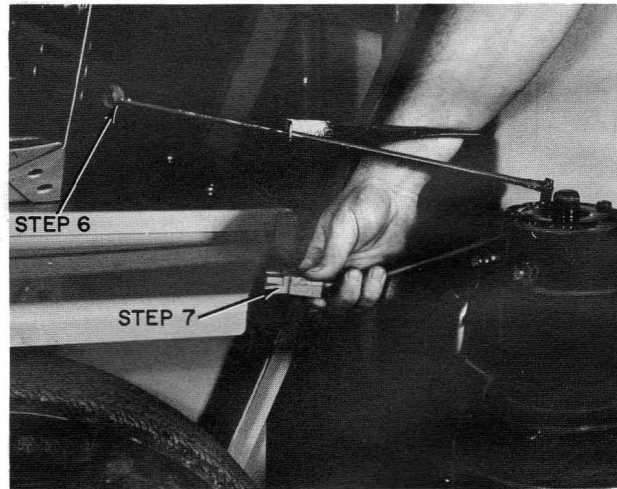

Figure 16

8. Raise the lift to allow the forks to be installed on the back plate.

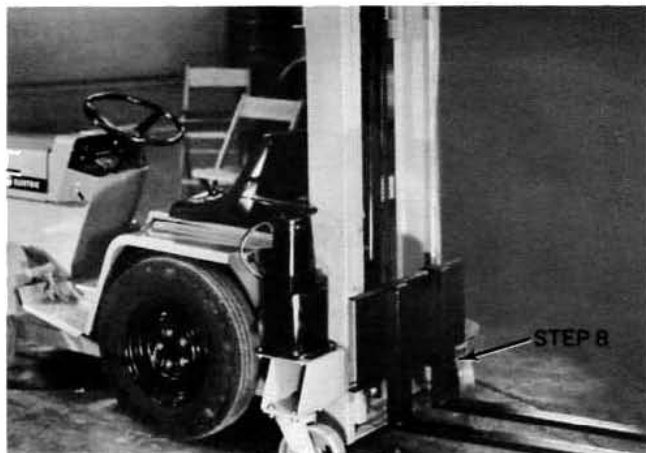
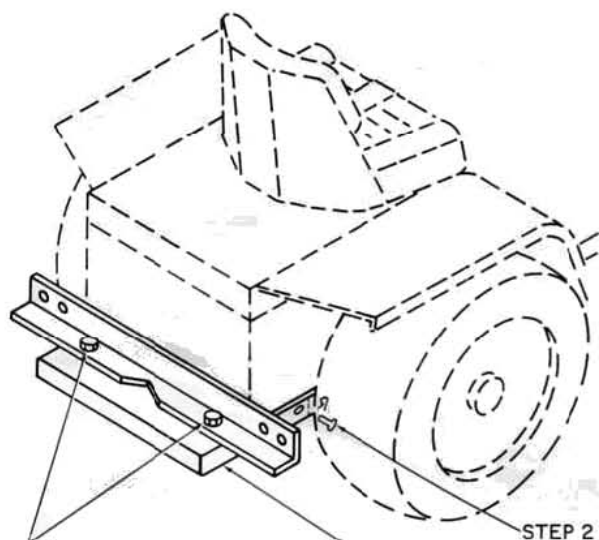

Figure 17

Removal follows these steps in the reverse order. **DO NOT ATTEMPT TO DRIVE OFF THE LIFT WITH THE TRIANGULAR MOUNTING BRACKETS IN PLACE!**

OVERHEAD GUARD INSTALLATION

1. Insert the adapter arms into the frame openings at the rear of the tractor. Push in fully.



STEP 3
PUSH ADAPTER IN FULLY. SQUARE AND CENTER ANGLE SUPPORT ON ADAPTER AND MARK AND DRILL TWO 7/16 INCH HOLES IN ADAPTER

Figure 18

2. Insert clevis pins through the frame holes to secure the adapter. Retain the clevis pins with hair pin cotters.

3. Lay the angle support across the adapter so that its center holes line up with the holes in the adapter, and its vertical side is closest to the tractor. Secure the angle support to the adapter with 3/8 x 1 inch bolts, lockwashers and nuts.

4. Install "U-bolts" in place at each end of the angle support so that their lockwashers and nuts are towards the tractor. (Do not tighten.)

5. Install the pipe frames in the front fender sockets and in the "U-bolts" at the rear of the tractor.

NOTE: The free ends of each pipe frame have a short straight section before its first bend. Install each frame so the shorter of the two sections is placed in the front fender sockets.

6. Lay the guard on top of the pipe frames so that the flat surfaces of the four corner mounting brackets are directly over the pipe frame. (The narrower spacing between pairs of mounting brackets determines the front of the guard.)

7. Secure the guard to the pipe frame with "U-bolts" around the frame and through the mounting brackets, using lockwashers and nuts. Center the guard and tighten the "U-bolts".

8. Tighten the "U-bolts" holding the pipe frames to the angle supports.

REMOVAL

To remove the overhead guard assembly, it is necessary only to loosen the "U-bolts" on the angle supports. The assembly can then be lifted free of the tractor and the adapter withdrawn from the frame without the need of further disassembly. Simply remove the clevis pins and withdraw the adapter from the tractor frame.

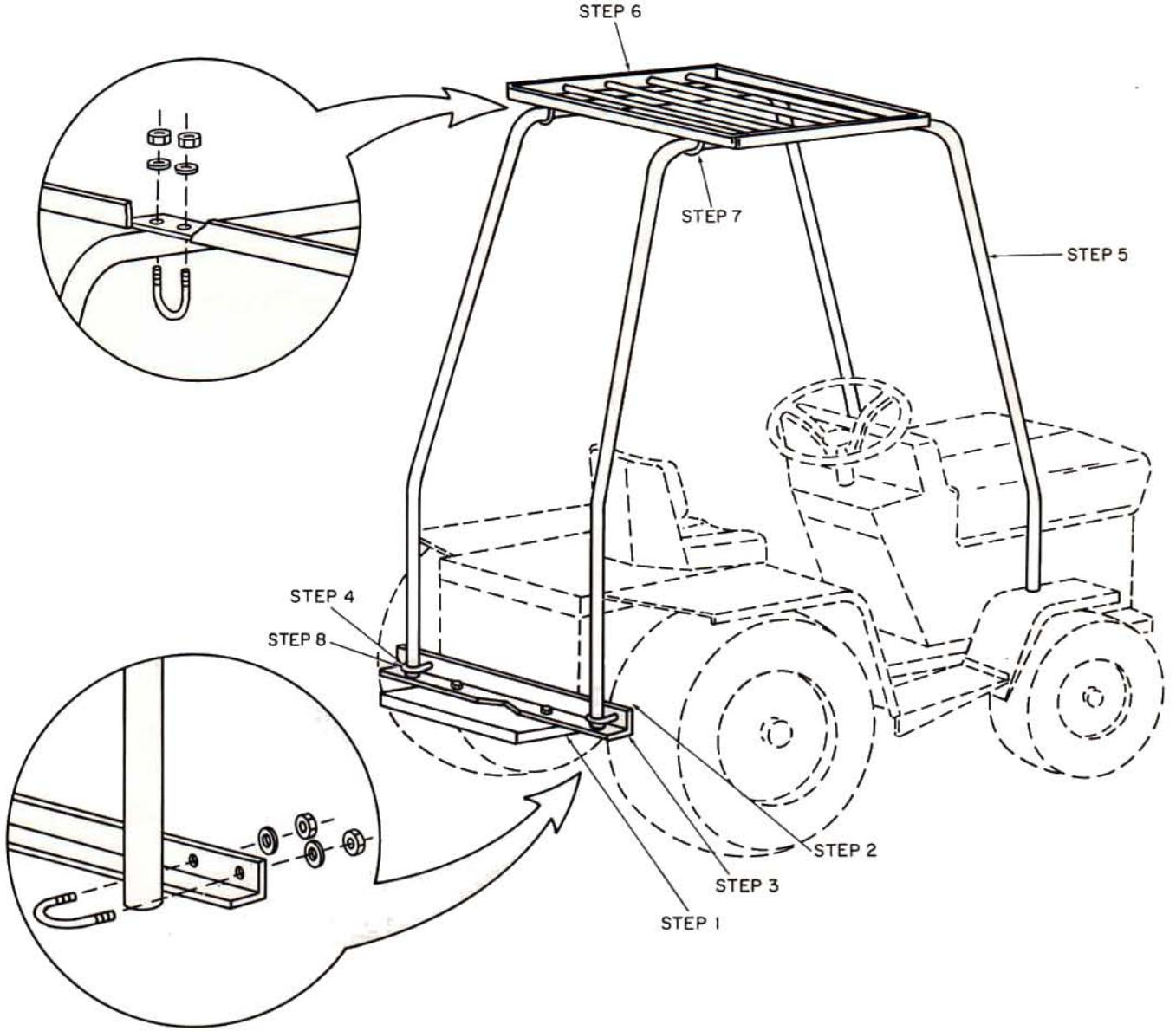

Figure 19