



INSTRUCTIONS

E10M PTO OUTLET KIT MODEL KD10

WARNING: Remove battery clamp terminating wire 2-01 from the positive post of battery B2 and replace the battery cover before proceeding with this installation. Do not lower the control panel on to the exposed battery terminals.

1. Place the supplied template on the outside of the grill in the upper portion of the center panel. See Figure 1A. The template is used to mark the location of 3 mounting holes to install the outlet.

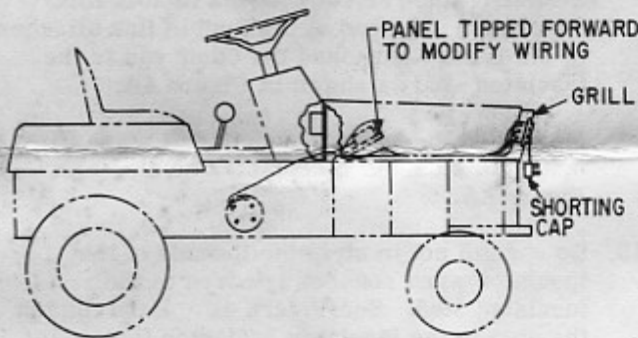

Figure 1

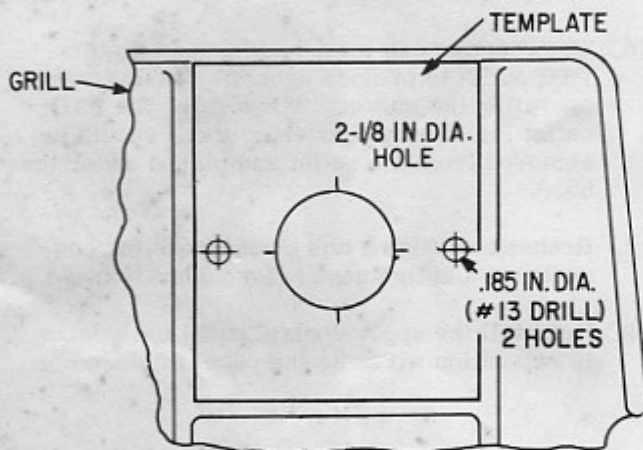

Figure 1A

2. Using a pencil or scribe, draw the outline of the 2-1/8 inch diameter hole using the template as a guide. If necessary, determine the

center of this hole by laying a straight edge across opposite pairs of registration marks on the circumference of the template, then drawing a line where it crosses the hole's center.

3. Center-punch the cross lines of the small 0.185-inch diameter mounting holes for accurate drilling. Make sure the template has not shifted since outlining the larger hole.
4. Cut the 2-1/8 inch diameter hole in the grill using the drawn outline as a guide.
5. Drill the two mounting holes using a 3/16-inch (#13) drill bit. Backing the grill with a block of wood will allow better drilling.
6. Install the PTO outlet on the back side of the grill as shown in Figure 2. Secure with a #8 Phillips Head screw, lockwasher and nut in each of the mounting holes, with the shorting-cap lead under one of the screw heads. The screw heads should be on the outside of the grill.

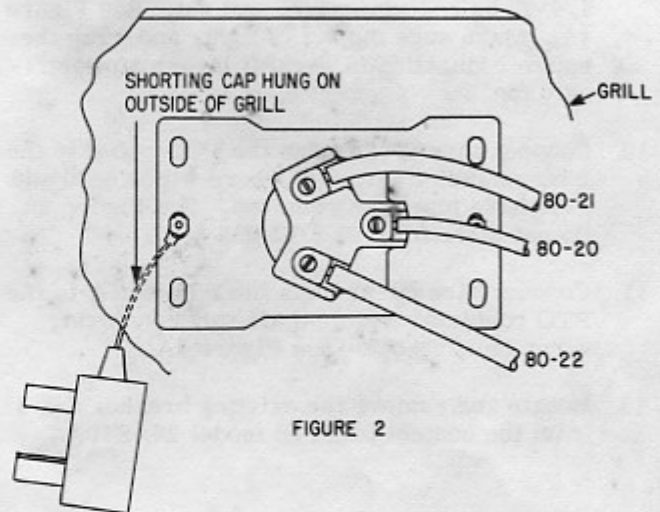

FIGURE 2

Figure 2

7. Attach furnished wires 80-20, 80-21 and 80-22 to the PTO outlet as shown in Figure 2. Dress these wires along the right side of the battery compartment as shown in Figure 3.

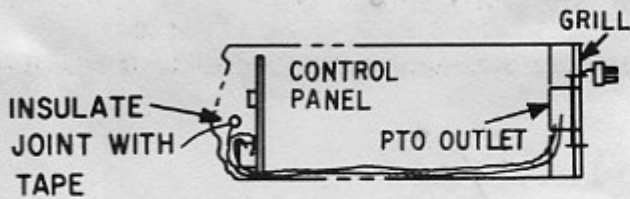

Figure 3

8. Lower the upper control panel so its mounted components are exposed (see Figure 1) and locate the PTO contactor, which is mounted on the right end of the panel. See Figure 4A.

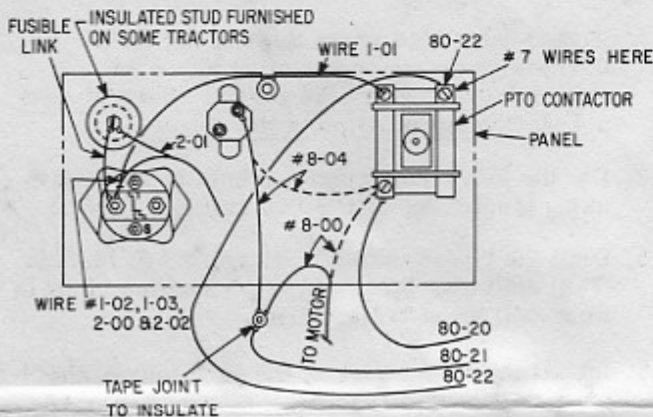

Figure 4A

9. Remove wire 8-00 (8 AWG) and 8-04 (10 AWG) from the PTO contactor and join them together with wire 80-21 from the PTO outlet with a 1/4-20 bolt, lockwasher, and nut. See Figure 4A. Make sure the nut is tight, and wrap the entire connection in several layers of electrical tape.
10. Connect wire 80-20 from the PTO outlet to the PTO contactor terminal where wires 8-00 and 8-04 have just been removed. See Figure 4A. Do not disturb wires 8-01 and 8-02.
11. Connect wire 80-22 from the PTO outlet to the PTO contactor terminal already connecting wires numbered 7. See Figure 4A.
12. Locate and remove the existing breaker CB-3 from the control panel on model 26AE10AA

and replace it with the insulated stud assembly provided as shown in Figures 4A and 4B. On other models the insulated stud assembly is already present, and the one furnished in the kit is not required.

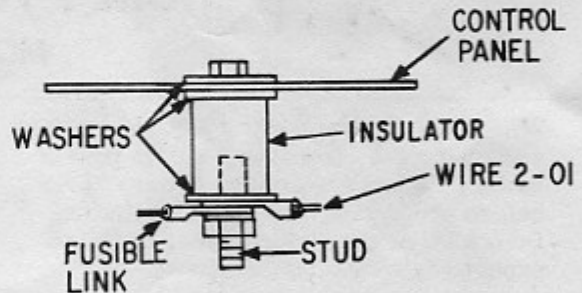

Figure 4B

13. Discard wire 1-00 between L contactor and CB-3 (if previously equipped) and replace it with the fusible link supplied. (Models with insulated studs already have a fusible link installed.) One end of the fusible link attaches to the L contactor, and the other end to the insulated stud as shown in Figure 4A.
14. Make the other wire connections to the insulated stud and L contactor as shown in Figure 4A.
15. Be careful not to strip the threads of the insulator when connecting wires to the insulated stud. See Figure 4B. Hand tighten the stud to the insulator. Tighten the nut to the stud and bolt to the insulator with 42-46 inch pounds of torque.
16. The shorting cap must be plugged into the PTO outlet to provide dynamic braking when operating the mower. When using the PTO outlet for other purposes, the cap should be removed from the outlet and placed under the hood.
17. Recheck all wiring and connections for correctness and tightness before operation.
18. Reinstall the upper control panel using care to reposition wires as the panel is closed.

PACKING LIST

E10M PTO OUTLET KIT

KD10AA (155C8162G1)

<u>QTY.</u>	<u>NAME</u>	<u>PART NUMBER</u>
1	OUTLET	243A4572P1
1	TEMPLATE	244A7449P1
2	SCREW, PHIL HD 8-32 x 1/2"	N80P15008B6
4	WASHER #8	N402AP38B6
2	LOCKWASHER #8	N405P8C6
2	NUT, HEX 8-32	N210P15B6
1	SCREW, PHIL HD 1/4-20 x 1/2"	N80P21008B6
3	LOCKWASHER 1/4"	N405P11C6
2	NUT, HEX 1/4-20	N210P21B6
1	CAP, SHORTING	244A7440G1
1	WIRE, MARKED 80-20	178B8298G2
1	WIRE, MARKED 80-21	178B8298G2
1	WIRE, MARKED 80-22	178B8298G1
1	FUSE LINK	211A3448G2
1	WASHER 1/4"	N402AP41B6
1	INSULATOR	211A3165P1
1	BOLT, HEX HD 1/4-20 x 5/8"	N22P21010B6
1	STUD 1/4-20 x 1 1/8"	N90P21018
3	WASHER 1/4"	N402AP71B6
1	INSTRUCTIONS	GEH4001