

INSTALLATION INSTRUCTIONS FOR HEAD  
LIGHT KIT ON EGT 80 AND EGT 100 TRACTORS.

PART NO. 120627.

**WARNING:** Remove battery clamp terminating wire 2-01 from the positive post of battery B2 and replace the battery cover before proceeding with this installation. Do not lower the control panel on to the exposed battery terminals.

1. Place the template with the large hole on the outside left corner (while facing the front of the tractor) of the grill. Allow the template to lay flush with the inside edge of the raised grill edge. See Figure 1.

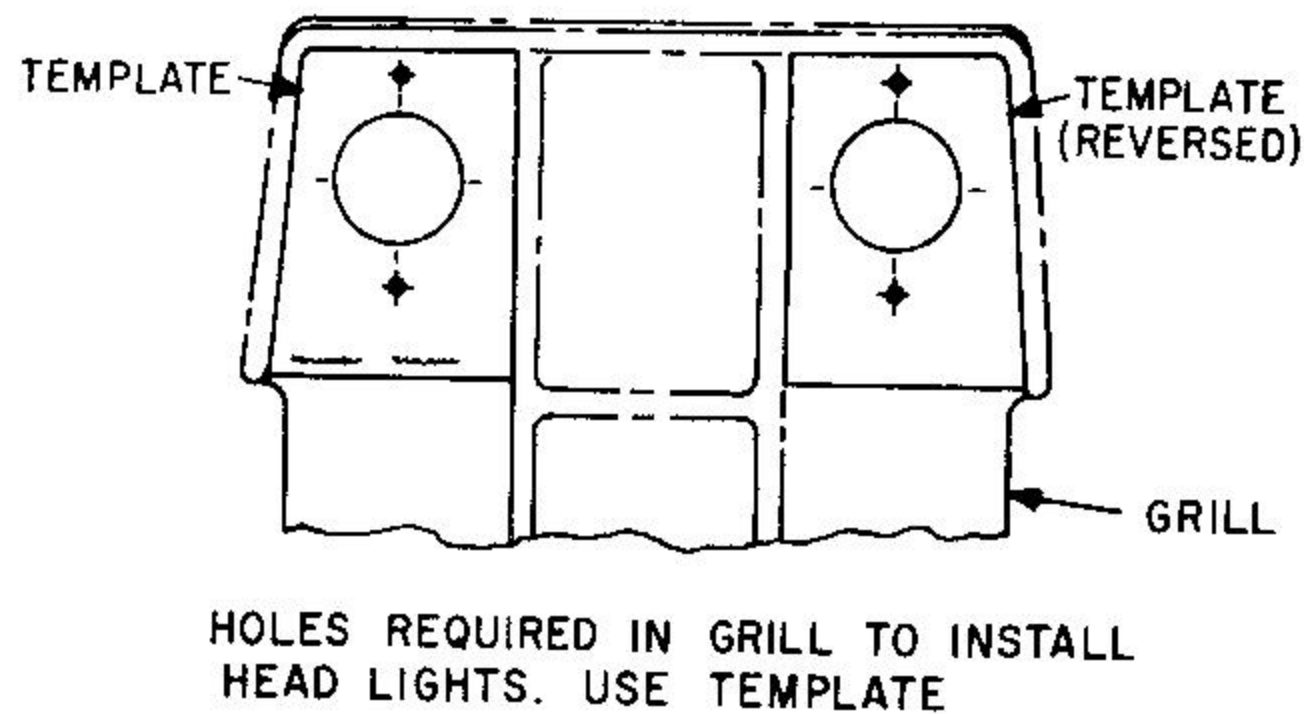

Figure 1

2. Using a pencil or scribe, draw the outline of the 2-1/8 inch diameter hole using the template as a guide. If necessary, determine the center of this hole by laying a straight edge across opposite pairs of registration marks on the circumference of the template and drawing a line where it crosses the hole's center.
3. Center punch the cross lines of the smaller template holes for accurate drilling. Make sure the template has not shifted since outlining the larger hole.
4. When the template is removed, the outline of the 2-1/8 inch and the centers of the mounting holes should be clearly marked.
5. Cut the 2-1/8 inch diameter hole using the outline of the template.

6. Drill the two 0.185-inch diameter mounting holes with a #13 drill bit.
7. Reverse the template and repeat steps 1 through 6 for the right corner of the grill.
8. Secure the socket assemblies to the brackets with 6-32 x 3/8-inch pan-head screws, lockwashers, and nuts as shown in Figure 2.
9. Secure each bracket assembly to the inside of the grill with 6-32 x 3/8-inch pan-head screws, lockwashers, and nuts as shown in Figure 2.

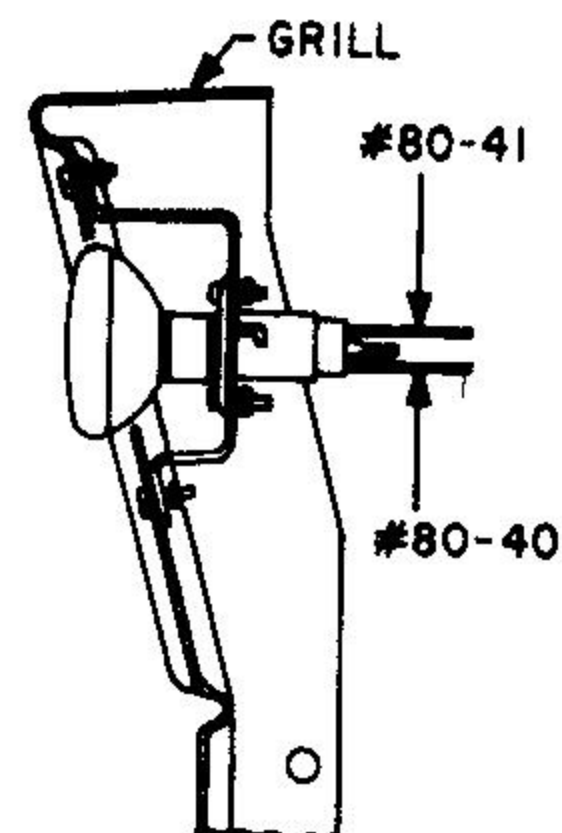

Figure 2

10. Lower the upper control panel so its mounted components are exposed as shown in Figure 3.

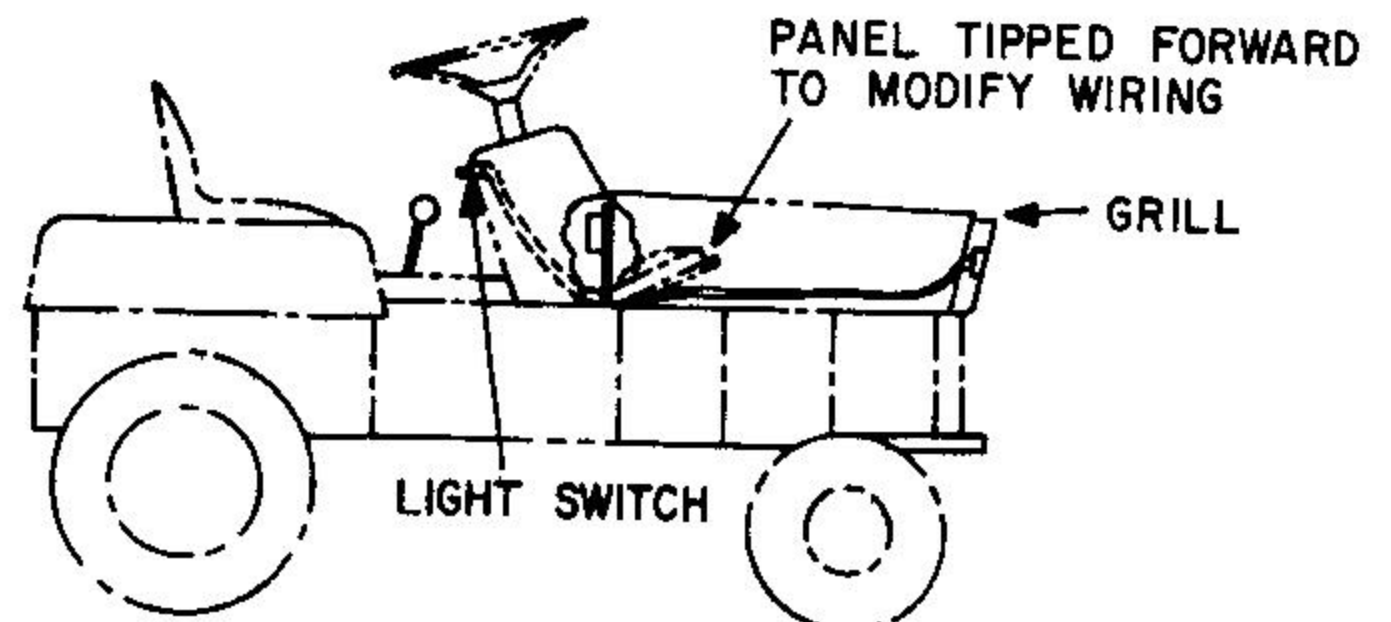
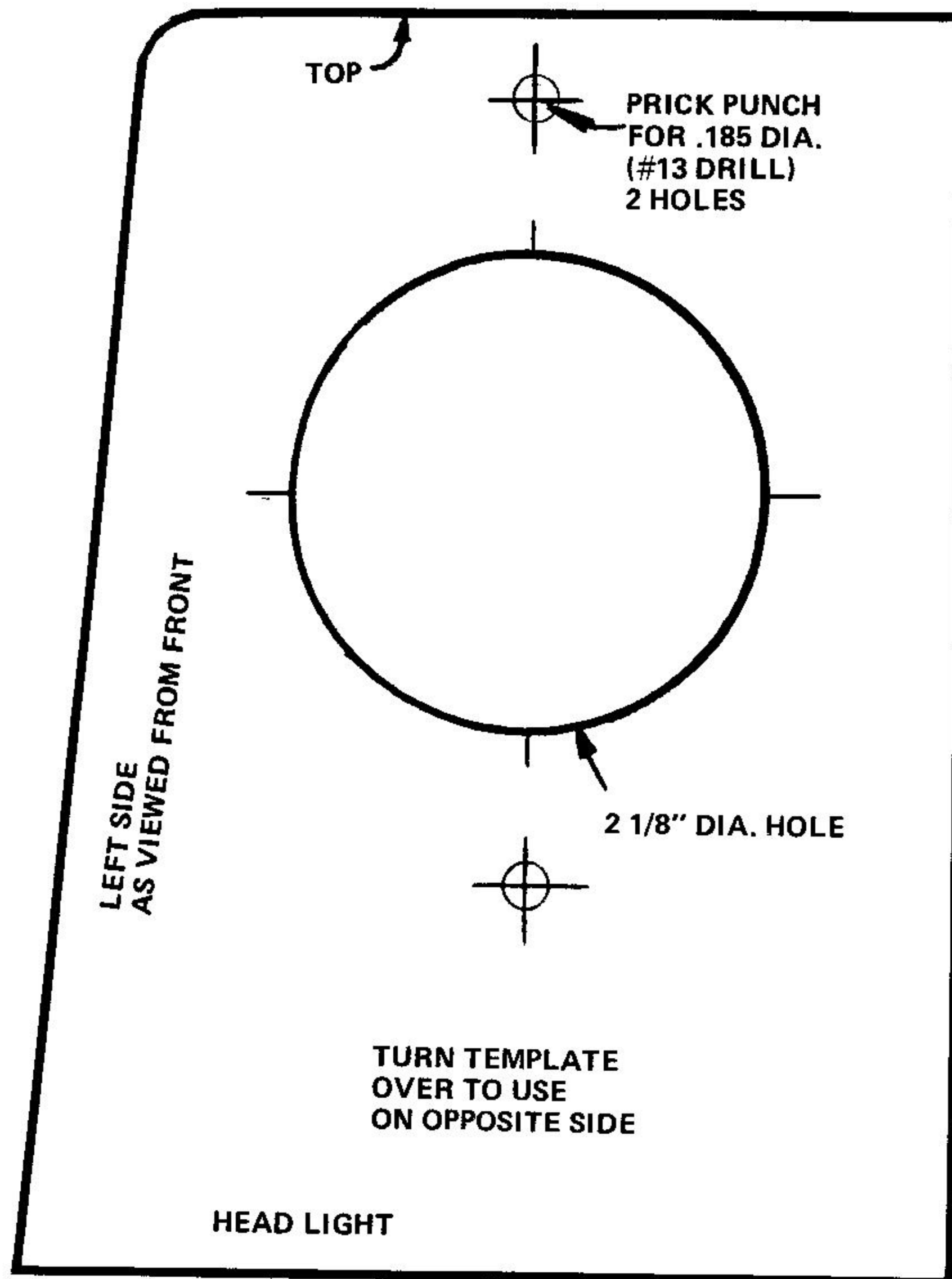
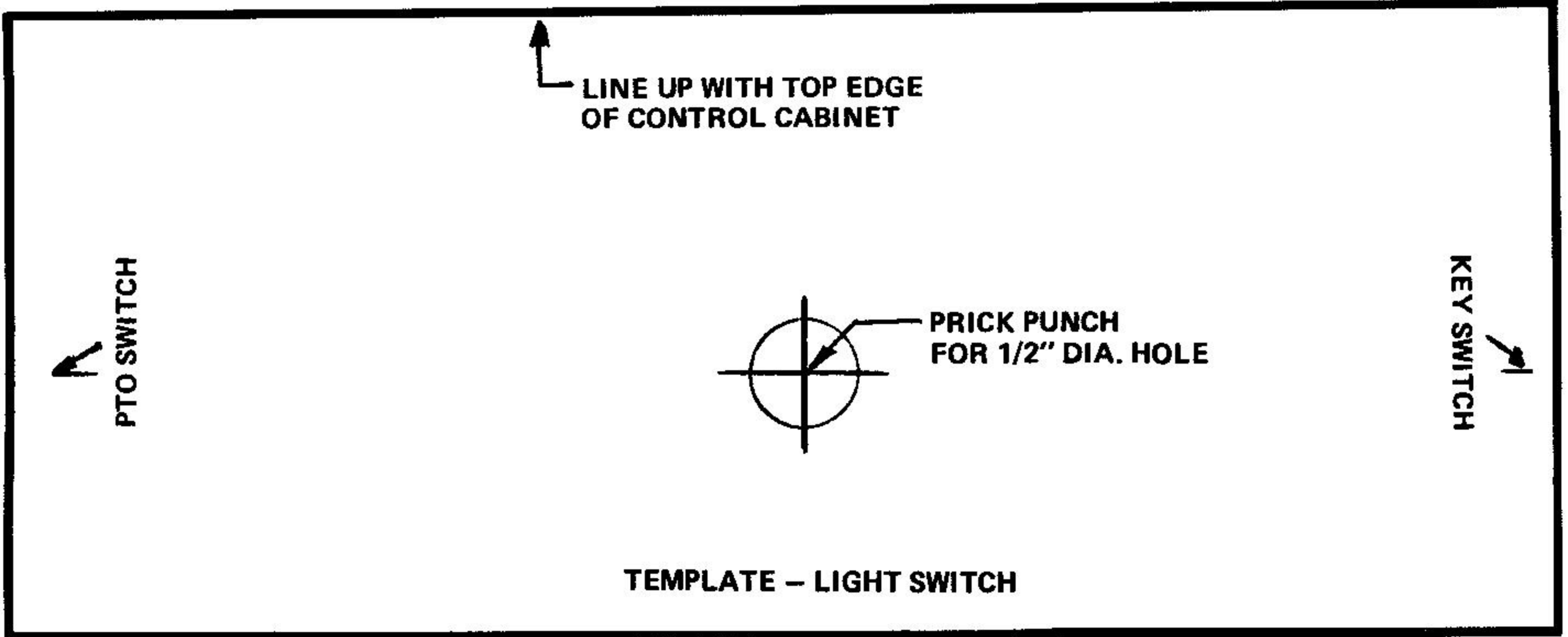
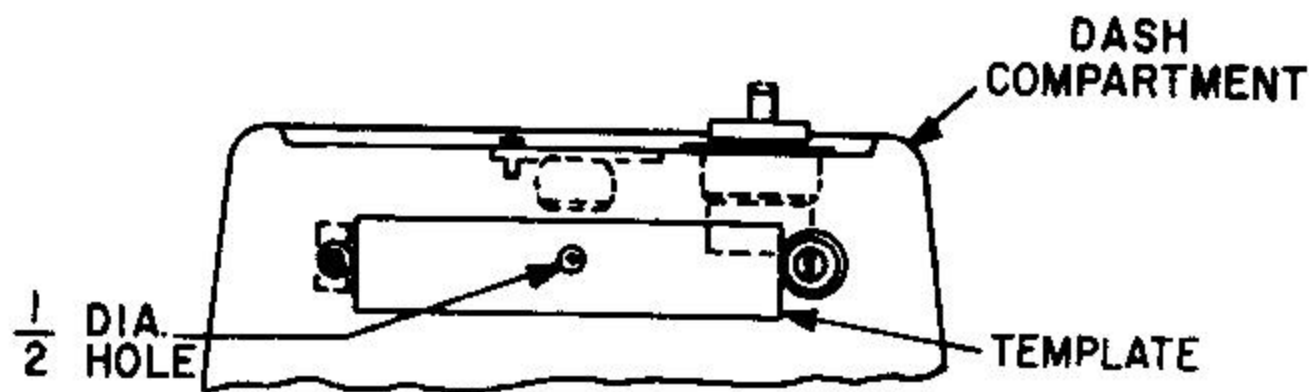

Figure 3



- Place the template for the switch mounting hole in line with, and between the PTO switch and the key switch as shown in Figure 4A, and center punch the cross-lines of the hole for accurate drilling.



HOLE REQUIRED IN DASH COMPARTMENT TO INSTALL LIGHT SWITCH

Figure 4A

- Remove the template and move the control cabinet wiring away from the hole to be drilled. Drill a 1/2-inch diameter hole as marked with the template.
- Mount the light switch as shown in Figure 4B.

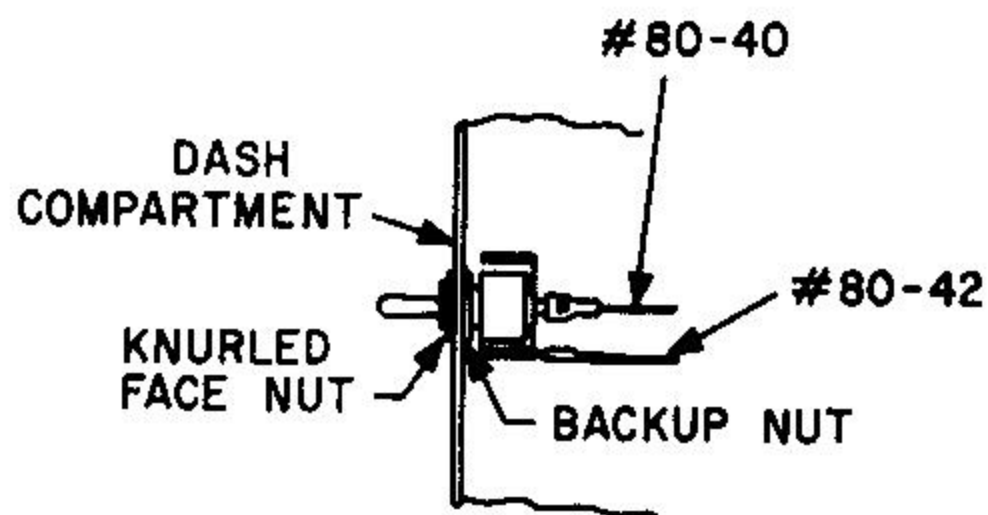

Figure 4B

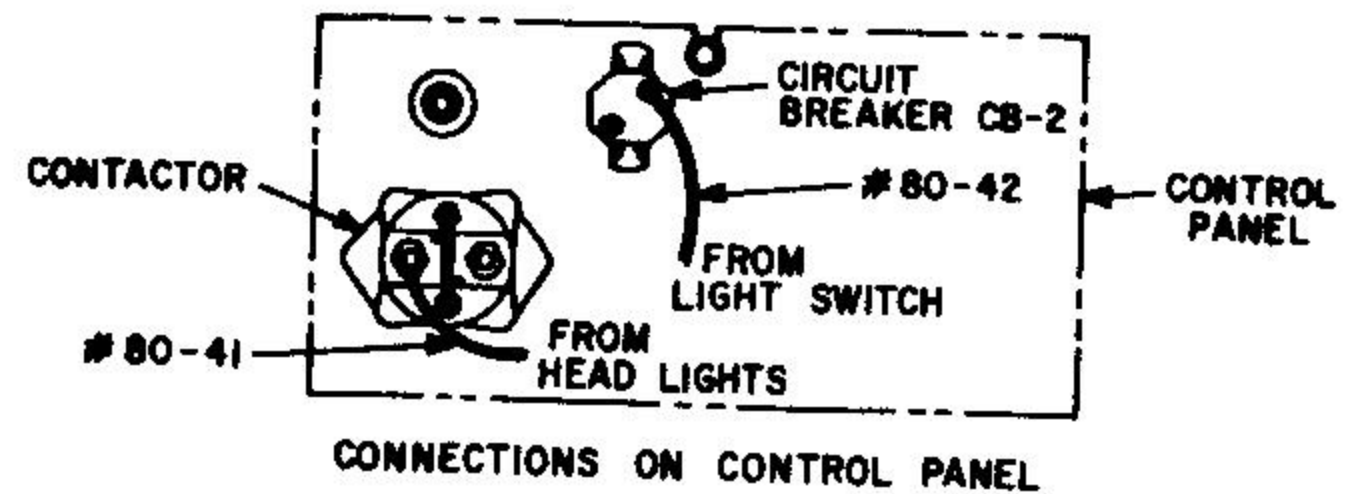

Figure 5B

- Attach furnished wires 80-40 and 80-42 to the rear of the light switch as shown in Figure 4B.
- Attach the free end of wire 80-42 to circuit breaker CB-2 where existing wires numbered 8 are attached, as shown in Figures 5A and 5B.
- Attach wires 80-40 and 80-41 to the headlights as shown in Figure 6.

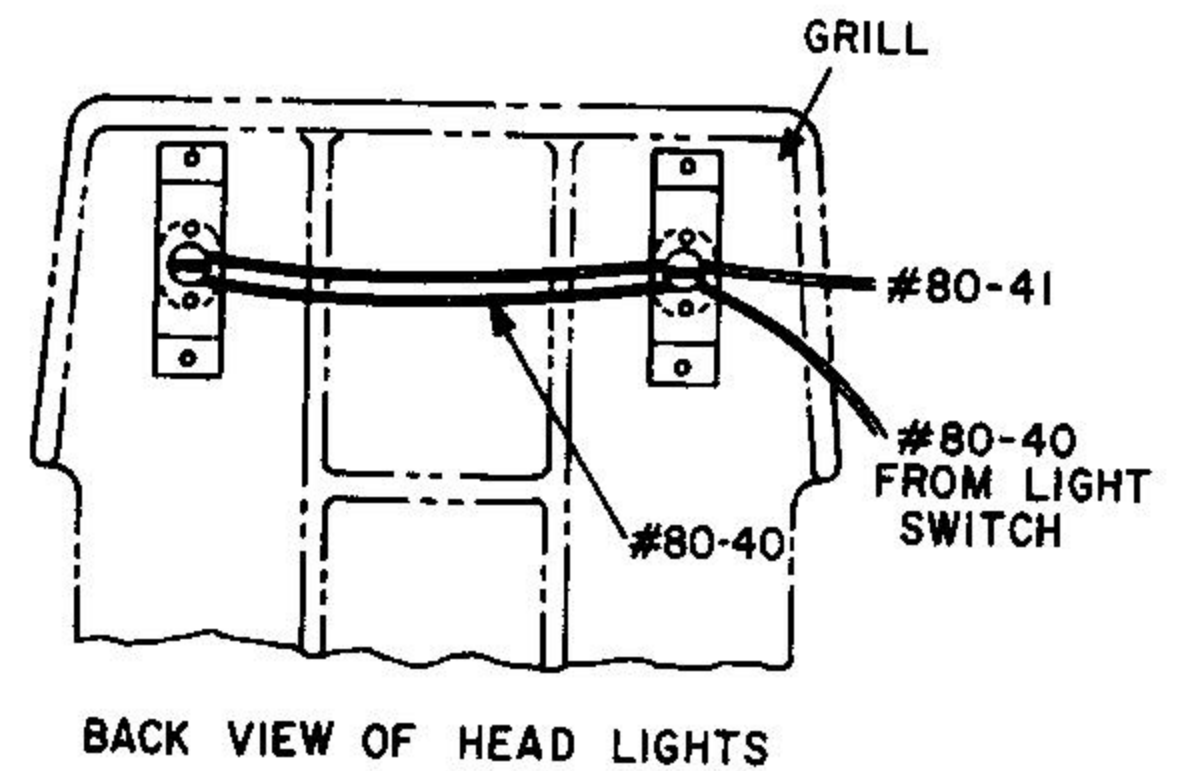

Figure 6

- Attach wire 80-41 to the L contactor as shown in Figure 5B.
- Recheck all wiring and connections for correctness and tightness.
- Reinstall the upper control panel using care to reposition the wires as the panel is closed.
- Reconnect the clamp to the positive terminal of battery B2.